



	Operating Weight	Max. Reach	Rated Power Gross
<b><i>DX225MH-5</i></b>	60,848 lb. (27,600 kg)	35' 5" (10,800 mm)	166 hp (124 kW)
<b><i>DX300MH-5</i></b>	79,366 lb. (36,000 kg)	42' 8" (13,000 mm)	271 hp (202 kW)
<b><i>DX210WMH-5</i></b>	57,221 lb. (25,955 kg)	35' 9" (10,900 mm)	186 hp (139 kW)

# **WHEN YOU CHOOSE DOOSAN**

as your heavy equipment brand, you'll have the backing of a strong, global organization – with benefits that extend far beyond the capabilities of a new machine.

**DOOSAN**



### **STRONG BRAND**

Doosan began in 1896. Its heritage in excavators goes back to 1978. Wheel loader production began in 1992, while the company's first articulated dump truck was designed in 1972. Throughout its years in the heavy equipment industry, Doosan has listened to its North American customers, making many improvements – and developing new machines – as a result of feedback from owners and operators. From 2005 to 2015, Doosan grew from its position as the seventh-largest construction equipment manufacturer in the world to the fifth-largest.

### **STRONG DEALERS**

Doosan serves you in partnership with its dealers – and similarly, your Doosan dealer is intended to be a trusted partner for you. Whether it's Doosan® parts, authorized service and maintenance, or even advice on how to get more value from your machine, Doosan dealers are behind you on every job.

### **STRONG EQUIPMENT**

Doosan products are known for reliably exceeding customers' most demanding expectations. It's why we're one of the fastest-growing heavy equipment brands in North America. Doosan offers crawler excavators, wheel excavators, compact excavators, wheel loaders, articulated dump trucks, log loaders, material handlers and a variety of job-matched attachments – all designed to perform in the most difficult working conditions.

### **STRONG NORTH AMERICAN OPERATIONS**

Doosan has a solid infrastructure to support your equipment from coast to coast. It includes parts distribution in Illinois and Ontario; service training, product management, sales and marketing support in Georgia; sales training and The Real Operation Center (ROC) customer experience facility in Arizona; plus attachment design and development in Minnesota.

### **STRONG WARRANTY**

Customers choose the months and hours of coverage in their transferable warranty. Options include a standard warranty of 12 months or up to 1,500 hours (depending on the machine), or up to the five-year, 7,500-hour Elite Assurance™ coverage for the powertrain only, the powertrain plus hydraulics or the full machine.

# PERFORMANCE

Made for scrap, solid waste, recyclables and other bulk materials, Doosan material handlers offer powerful hydraulic forces with high horsepower and torque to move mountains of material. Its low-emission engine utilizes high pressure common rail (HPCR) fuel injection for superior top-end performance and strong low-end torque rise. Powerful arm forces and a strong, durable grapple allow you to quickly, precisely tackle more cubic feet of material each day.

## Arm Forces

Superior hydraulics deliver ample power to the arm and bucket for lifting and loading heavy material.

## More Horsepower

Material handling isn't easy. Optimized horsepower gives you better performance for tough applications and heavy objects.

## Swing Torque

Doosan models have strong and productive swing torque that allows the material handler to swing heavy loads quickly, even uphill.

## Lift Work Mode

Doosan material handlers allow you to set a lift work mode that provides increased pump torque, low engine rpm and an automatic power boost to optimize workgroup performance for maximum productivity.

## Wheel Undercarriage (DX210WMH-5)

For jobsites requiring more mobility and maneuverability, the wheel undercarriage on the DX210WMH-5 makes every corner of your jobsite more accessible. An ergonomic steering wheel makes it simple and intuitive to control machine movement.

## Front and Rear Stabilizers

Stabilizers widen the machine's footprint, providing support that maximizes lift capacity and productivity.

## Rear Fixed Axles

The rear axle is fixed for excellent controllability and easy maintenance. The transmission is mounted to the rear axle for optimal ground clearance and protection from obstacles.

## One-Touch Power Boost

The convenient button on the right-hand joystick provides momentary increased hydraulic power for use on difficult loads that can slow other machines down.



## Selectable Power Modes

Selectable power modes give you more control over your material handler's performance. Manage the balance of fuel consumption and machine power to your preference, and customize performance to the task.





### Lifting Capacity

Lift more with each cycle and complete the job faster. Doosan material handlers are designed to maximize lifting capability. With an optimal loading reach, loading height and lift position, you can lift and place material with total confidence.

### Straight Boom and Droop-Nose Arm

The straight boom improves reach and lift height for better material placement, while the droop-nose arm gives enhanced access to containers, trucks and railcars.

**P+** **Power+ mode** delivers the fastest workgroup speeds to save more time when loading trucks, railcars and containers.

**P** **Power mode** provides excellent power and superior performance for heavy lifting. It also provides quick truck loading and fast travel speed to save time.

**S** **Standard power mode** optimizes your fuel consumption and delivers high performance for lifting.

**E** **Economy mode** reduces fuel consumption for low-demand applications and slows down machine movement, which is handy for tight-fitting areas that require extra precision.

Each Doosan material handler delivers fast cycle times and efficient operation to maximize operator productivity.

## Fast Cycle Times

Two variable displacement axial piston pumps deliver superior cycle times while hydraulic flow regeneration maximizes efficiency. The best-in-class hydraulics deliver ample power to the arm and grapple, allowing for fast, efficient material placement.

## Fuel Efficiency

The Doosan material handler's efficient horsepower curve delivers increased torque while using less fuel. Its high pressure common rail fuel injection system aids in reducing emissions and allows the T4-compliant engine to save fuel and improve performance.

### Auto Shutdown\*

When auto shutdown is enabled, operators can configure the idle time before the material handler shuts down automatically – from three to 60 minutes – to save valuable fuel for more productive operation.

*\*Auto shutdown and auto idle are disabled with generators installed.*

### Auto Downshift

On the DX225MH-5 and DX300MH-5, auto downshift reduces hydraulic flow when turning, pushing and maneuvering – so the machine doesn't bog down during travel. When the load decreases, the material handler automatically shifts back into high range.

### Auto Idle\*

The standard auto idle feature automatically idles your engine when machine functions are not used for four seconds. This reduces noise, improves jobsite communications and saves fuel. When you move the controls, the material handler automatically returns to your previous throttle setting.

### Optional Straight Travel Pedal

A straight travel pedal option allows you to travel in a straight line more easily, increasing your efficiency during travel. The optional straight travel pedal is available for the DX225MH-5 and DX300MH-5 models.



### Tier 4 (T4) Compliant

Optimized to provide more power output with reduced fuel consumption, Doosan material handlers are designed with T4-compliant engines to reduce air pollution.



### Cooled Exhaust Gas Recirculation (CEGR)

CEGR recycles a portion of the engine exhausts to reduce oxygen (O) and lower the temperature in the combustion chamber. This reduces nitrogen oxide (NOx) emissions.

### Diesel Oxidation Catalyst (DOC)

In the DOC, carbon monoxide (CO) and particulate matter (PM) emissions are transformed into harmless water (H<sub>2</sub>O) and carbon dioxide (CO<sub>2</sub>).

### Evaporative Module

In the evaporative module, or mixing pipe, diesel exhaust fluid (DEF) solution is injected in small doses mixed with hot exhaust gases, decomposing it into urea (CO(NH<sub>2</sub>)<sub>2</sub>) and water vapor, which then catalyzes into carbon dioxide and ammonia (NH<sub>3</sub>).

### Selective Catalytic Reduction (SCR)

In the SCR canister, nitrogen oxides mix with ammonia, and a chemical reaction takes place, resulting in nitrogen (N) and water vapor emitting from the system. The SCR canister also acts as the silencer or muffler.

### Diesel Exhaust Fluid (DEF)

DEF is a solution of pure urea and deionized water. A minimum level of DEF is required for proper machine operation, and the DEF supply tank is heated for proper operation in cold weather. DEF is available from your Doosan dealer in various container sizes.

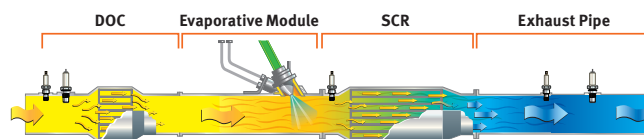

## ***DURABILITY/RELIABILITY***

One look at a Doosan material handler, and you can tell it's made to withstand the harsh jobsites where you spend your time. The machine is well-protected with solid construction and heavy-duty features that keep you working productively with fewer repairs.



### **D-Channel Frame Design**

This innovative upper-structure frame design adds strength to withstand more side shock and protect vital machine components.







### Machine Guarding

Strategic guarding on the Doosan material handler protects components from harsh material and debris, minimizing downtime.

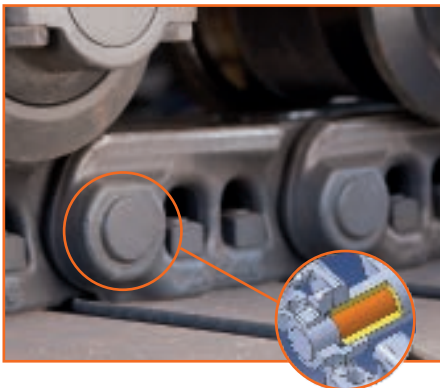

### Permanently Sealed, Lubricated Track Pins (DX225MH-5, DX300MH-5)

Pin links on tracked Doosan material handlers are permanently sealed. They never need greasing. That means you reduce your operating costs and increase your uptime.

### Variable-Speed Cooling Fan

The hydraulic oil cooler (DX300MH-5 only) utilizes a variable-speed hydraulically driven cooling fan. The speed of the fan changes as required by the demands of your material handler. When doing harder work, the fan runs faster for optimized cooling. When you're in lighter duty conditions, the fan runs slower to increase efficiency and reduce noise.

### Automatic Belt Tensioner

A spring-applied automatic belt compensates for regular wear and maintains a constant tension on the engine accessory belt.

### Air-to-Air Fuel Cooler

The air-to-air fuel cooler reduces fuel temperature to increase your machine's overall efficiency and protect engine components.

### Split Cooling

The split cooling system (DX300MH-5 only) allows the oil cooler and radiator to operate independently to ensure optimal hydraulic system and engine temperatures, even in severe working conditions. The system increases cooling capacity while protecting and extending the life of engine components.



### Recessed Drive Motors (DX300MH-5, DX225MH-5)

The drive motors are protected by a heavy-duty cover to protect mobility in severe conditions. On the outside of the tracks, the drive motors are recessed, offering further protection against potential damage and maximizing uptime.



# OPERATOR COMFORT

An operator can't push performance to the limit if the cabin isn't comfortable. Doosan knows how essential comfort is on long, hard days. From its great visibility to its deluxe, adjustable seat, Doosan cabins are easy to enter and exit, and they give you awesome standard features that bring superior comfort to the job.

## Adjustable Comfort

The standard air suspension seat has multiple adjustment points, allowing you to select the most comfortable position. The seat and control stand move with the suspension, maximizing comfort in all working conditions.

- A Control Stand/Seat Base Fore/Aft
- B Control Stand/Seat Height
- C Seat Fore/Aft
- D Seat Cushion Fore/Aft
- E Seat Cushion Angle
- F Back Recline
- G Lumbar Support
- H Headrest Fore/Aft and Up/Down
- I Control Stands Up/Down
- J Seat Heater (Opt.)

*The DX210WMH-5 with steering wheel is shown here. Other material handlers have travel control levers and pedals.*

## Comfortable Cab

The spacious FOPS/ROPS cab is fully equipped with comfort features that include heating and air conditioning with adjustable airflow and five operating modes. The standard reclining, height- and weight-adjustable seat (with headrest, adjustable armrest and seat belt) offers excellent lumbar support. An optional air suspension seat sets the comfort standard even higher. The pressurized cab keeps the operator environment cleaner, too.

## Other Cabin Features

- Improved floor space for your feet, and increased cab space for your legs, arms and head
- 180-degree swinging door
- Wide entry/exit area
- Grab handles and punched panel steps
- Standard radio and whip antenna (CD player and MP3 player input are optional)
- 12V power port
- Adjustable side window openings for fresh air



## Visibility

Sightlines are critical for operator performance, and Doosan material handlers provide the best possible view from inside the cab. The cab has large front and side windows, narrow corner pillars with small window joints, plus a pillar-mounted wiper. It all gives operators a more unobstructed view. An overhead window enhances your ability to see when loading trucks or working overhead, and a rearview camera improves visibility in back. Sun shades on the front and top windows also shield the eyes from sunlight.



### Fixed Cab Riser (DX225MH-5, DX300MH-5)

The standard, fixed cab riser provides an excellent view of your attachment and work area for maximum productivity. The cab and riser can be hydraulically lowered for transport.



### Hydraulic Elevating Cab (DX210WMH-5 – Standard) (DX225MH-5, DX300MH-5 – Option)

With increased hydraulically controlled variable cab height, you can set your vantage point for an optimal view of your attachment and work area, allowing for maximum productivity.

## Simple Controls

All Doosan material handlers include ergonomic, proportional joystick-control levers and foot pedals. The easy-to-read, color LCD monitor provides real-time information to the operator.



## Lighting Options

Optional lighting includes four LED working lights in front and two LED working lights in back to provide plentiful light before sunrise or after sunset.

## Quiet Operation

A complete, sound-isolating seal reduces the noise inside the cabin to an extremely low level. The compartmentalized components reduce noise output outside the cab. Even the cabin frame and seat are designed to absorb vibration to significantly increase operator comfort.

## Automotive Style Heat and Air Conditioning

High-capacity heating and cooling vents, and an easy-to-control temperature, keep you comfortable in every season. Automatic temperature control senses and adjusts to the temperature setting automatically. A memory function returns it to your preferred temperature if you shut the machine off and restart later.



## Easy-to-Read LCD Display Panel

An easy-to-read, easy-to-reach LCD panel enables monitoring of critical machine data, such as coolant temperature, fluid levels, warnings and the rearview camera display. Selectable power modes and work modes, plus preset hydraulic attachment management (via the LCD screen) allow operators to match performance to the job requirements. The display switches to a night view during low-light operation.

## Standard Rearview Camera

A rearview camera provides the operator with an additional means of viewing machine surroundings for enhanced productivity. An optional side camera is available, and both cameras can be viewed at once on the LCD panel.



## EASE OF MAINTENANCE

Even the best equipment needs regular maintenance, but it needs to be as easy as possible. Doosan simplifies material handler care with onboard diagnostic systems, easy component access and a standard fleet management system. If you want a long-lasting machine that takes minimal effort to keep it running at peak productivity, Doosan delivers everything you need.

### Easy Component Access

Access panels are easy to find and open from the top, bottom and sides of the material handler. A large engine bonnet provides plenty of room to reach the top of the engine, while a hinged belly pan allows access from the bottom. Solid steel side panels provide access to regular daily maintenance items, which makes for quick, easy service and a lower cost of operation.

# DOOSAN<sup>®</sup>

## CONNECT<sup>®</sup>

Durable monitoring hardware is built into your Doosan machine, and it collects reliable, accurate and robust data with every minute of operation. The data is uploaded automatically to the Doosan Connect online system using dual-mode communications (cellular and satellite) for maximum coverage. Your designated users can monitor the machine status from anywhere using the Doosan Connect website and mobile application.

*Key benefits include:*

- Critical code awareness or proactive service
- Preventative maintenance planning
- Operational efficiency management
- Location visibility

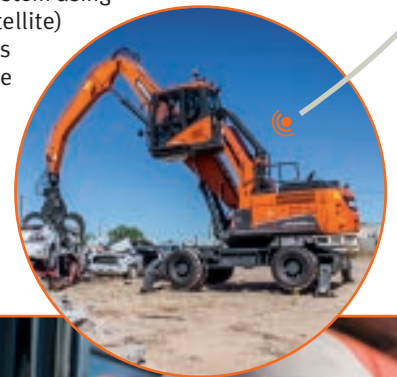

### Self-Diagnostics

The LCD monitor helps you monitor critical systems in real time. Plus, you can access historical machine alerts right from the screen in the cabin.



### Oil and Filter Life

Easily review the hours since the last maintenance for oils and filters. Ten hours before service is due, the machine will remind you when oils and filters need replacing, which helps ensure regular maintenance scheduling.



### Emergency Stop Switch

The relocated emergency stop switch is easy to access from the machine's exterior.

### Auxiliary Mode Switch

If needed, an auxiliary mode switch allows you to finish a task in progress, or move your material handler to a more convenient location for service.

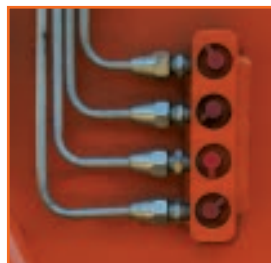

### Centralized Arm and Boom Grease Points

Daily maintenance is critical – and it's simple with the centralized grease banks on the arm and base of the boom.

### Doosan Monitoring System with Dealer Laptop Access

The Doosan monitoring system is a diagnostic program that gives your dealer's technician a direct communications link with your material handler. During operation, it monitors all critical data and provides a complete history of operation and a real-time log of machine failures. Armed with information like this, your dealer service personnel can fix issues fast – and you can get back to work.

### Color-Coded, Labeled Wiring

Wiring in the machine is labeled for easy service, fast troubleshooting and simple installation of electronic accessories – like the rotating beacon.

**VERSATILITY**



Doosan attachments are designed to match your material handler's load ratings and hydraulics for the best possible performance. The machine itself offers a variety of features that make attachment operation easy, intuitive and productive.

### **Control Pattern Change Valve**

Change the preferred control pattern to match operator preferences.

### **Rotating-Grapple Ready**

The Doosan material handler is ready to work with a rotating grapple attachment. There are no additional hydraulics to install or add as an expensive option.

### **Grapple Attachment**

Built for maximum power and reliability in harsh material-handling applications, the Doosan grapple rotates 360 degrees and has four hydraulic tines to grab and hold tightly to large, irregular-shaped loads.

- Includes lift eye for an underslung magnet
- Slew drive motor includes internal reliefs, hose kit and mount
- Replaceable tine tips simplify maintenance



### **Generator and Magnet**

To increase versatility for ferrous metal sorting and loading, choose the 15kW generator set, available as a factory- or dealer-installed option. An optional deep-field magnet set is also available, and it can be slung under the grapple or connected directly to the arm.



### **Attachment Management**

Via the LCD screen, the operator can configure different attachment presets to limit the maximum pressure and the minimum/maximum flow rate delivered to the attachment. Password protection functionality within the system prevents improper attachment preset selection for operators with limited understanding of hydraulic systems.

## General

### STANDARD CONFIGURATION

	UNIT	DX225MH-5 Material Handler (US90)	DX300MH-5 Material Handler (US90)	DX210WMH-5 Material Handler (US90)
<b>ENGINE</b>				
MAKE		Doosan	Scania	Doosan
MODEL		DL06K	DC09	DL06P
NUMBER OF CYLINDERS		6	5	6
RATED POWER GROSS (HP PER SAE J1995)	hp (kW) @ rpm	166 (124) @ 1800	271 (202) @ 1800	189 (141) @ 1900
RATED POWER NET (HP PER SAE J1349)	hp (kW) @ rpm	162 (121) @ 1800	267 (199) @ 1800	186 (139) @ 1900
MAXIMUM TORQUE (GROSS) (SAE J1995)	ft.-lb. (Nm) @ rpm	557 (750) @ 1400	940 (1275) @ 1300	593 (804) @ 1400
PISTON DISPLACEMENT	in. <sup>3</sup> (L)	359 (5.9)	568 (9.3)	359 (5.9)
BORE AND STROKE	in. x in. (mm x mm)	3.9" x 4.9" (100 x 125)	5.1" x 5.5" (130 x 140)	3.9" x 4.9" (100 x 125)
STARTER	V, hp (kW)	24V, 8 (6)	24V, 8 (6)	24V, 6 (4.5)
BATTERY (QTY 2)	V,AH	2 x 12V, 150AH	2 x 12V, 200AH	2 x 12V, 150AH
ALTERNATOR		24V, 80 A	24V, 100 A	24V, 80 A
AIR CLEANER		Double Elements	Double Elements	Double Elements
<b>HYDRAULICS</b>				
MAIN PUMPS	gpm (L/min.)	2 x 55 (2 x 207)	2 x 66 (2 x 248)	2 x 62 (2 x 236)
PILOT PUMP (GEAR DESIGN)	gpm (L/min.)	7.1 (27)	7.1 (27)	7 (27)
RELIEF PRESSURE (NORMAL)	psi (kg/cm <sup>2</sup> )	4694 (330)	4978 (350)	4694 (330)
RELIEF PRESSURE (BOOST)	psi (kg/cm <sup>2</sup> )	4978 (350)	5263 (370)	4978 (350)
<b>MAXIMUM SYSTEM PRESSURE</b>				
BOOM/ARM (NORMAL MODE)	psi (kg/cm <sup>2</sup> )	4694 (330)	4978 (350)	4694 (330)
BOOM/ARM/BUCKET (POWER MODE)	psi (kg/cm <sup>2</sup> )	4978 (350)	5263 (370)	4978 (350)
TRAVEL (NORMAL MODE)	psi (kg/cm <sup>2</sup> )	4694 (330)	4978 (350)	4694 (330)
TRAVEL (POWER MODE)	psi (kg/cm <sup>2</sup> )	4978 (350)	5263 (370)	4978 (350)
SWING (NORMAL MODE)	psi (kg/cm <sup>2</sup> )	4694 (330)	4978 (350)	4694 (330)
SWING (POWER MODE)	psi (kg/cm <sup>2</sup> )	4978 (350)	5263 (370)	4978 (350)
<b>UNDERCARRIAGE</b>				
UPPER ROLLERS (EACH TRACK)		2	2	N/A
LOWER ROLLERS (EACH TRACK)		8	9	N/A
NUMBER OF SHOES (LINKS PER SIDE)		49	48	N/A
TOTAL LENGTH OF TRACK	ft.-in. (mm)	14' 7" (4445)	16' 2" (4940)	N/A
WHEELBASE	ft.-in. (mm)	N/A	N/A	9' 4" (2850)
<b>SWING MECHANISM</b>				
SWING SPEED	rpm	0 - 10.9	0 - 9.9	0 - 9.8
SWING TORQUE	lbf.-ft. (kgf.m)	60,757 (8400)	87,787 (12,137)	46,197 (6387)
<b>DRIVE SYSTEM</b>				
TRAVEL SPEED (LOW – HIGH)	mph (km/h)	1.9 - 3.4 (3.0 - 5.5)	1.9 - 3.3 (3 - 5.3)	2.5 - 5.6 - 22 (4.0 - 9.0 - 35)
TRACTION FORCE (DRAWBAR PULL)	lbf (kgf)	60,715 (27,540)	83,258 (37,765)	26,742 (12,130)
MAXIMUM GRADE	% (°)	70% (35°)	70% (35°)	60% (31°)
<b>ENVIRONMENT</b>				
SOUND LEVEL (2000/14/EC)	dB(A)	102	103	102
CABIN SOUND LEVEL (ISO 6396)	dB(A)	70	71	72
<b>REFILL CAPACITIES</b>				
FUEL TANK	gal. (L)	105.7 (400)	132.1 (500)	79.3 (300)
DEF TANK	gal. (L)	9 (35)	18.5 (70)	8.3 (31.5)
COOLING SYSTEM (RADIATOR CAPACITY)	gal. (L)	5.9 (22.3)	12.9 (49)	6.3 (24)
ENGINE OIL	gal. (L)	7.1 (27)	9.5 (36)	6.6 (25)
SWING DRIVE	gal. (L)	1.3 (5)	1.8 (7)	1.3 (5.0)
FINAL DRIVE (EACH SIDE)	gal. (L)	0.9 (3.3)	1.8 (7)	0.7 (2.5)
FRONT AXLE	gal. (L)	N/A	N/A	2.91 (11.00)
FRONT HUB (2X)	gal. (L)	N/A	N/A	0.66 (2.5)
REAR AXLE	gal. (L)	N/A	N/A	3.83 (14.50)
REAR HUB (2X)	gal. (L)	N/A	N/A	0.66 (2.5)
TRANSMISSION	gal. (L)	N/A	N/A	0.66 (2.5)
HYDRAULIC SYSTEM	gal. (L)	63.4 (240)	81.9 (310)	74 (280)
HYDRAULIC TANK	gal. (L)	37 (140)	43.6 (165)	54 (205)

Note: Where applicable, dimensions are in accordance with Society of Automotive Engineers (SAE) and ISO standards. Specifications and design are subject to change without notice. Pictures of Doosan material handlers may show other than standard equipment. All dimensions are shown in inches. Respective metric dimensions are enclosed by parentheses. Doosan equipment is manufactured with a Quality Management System that is in compliance with ISO 9001:2008.

All dimensions are given for Doosan material handlers equipped with standard tracks or tires and the standard front as listed.



# Dimensions

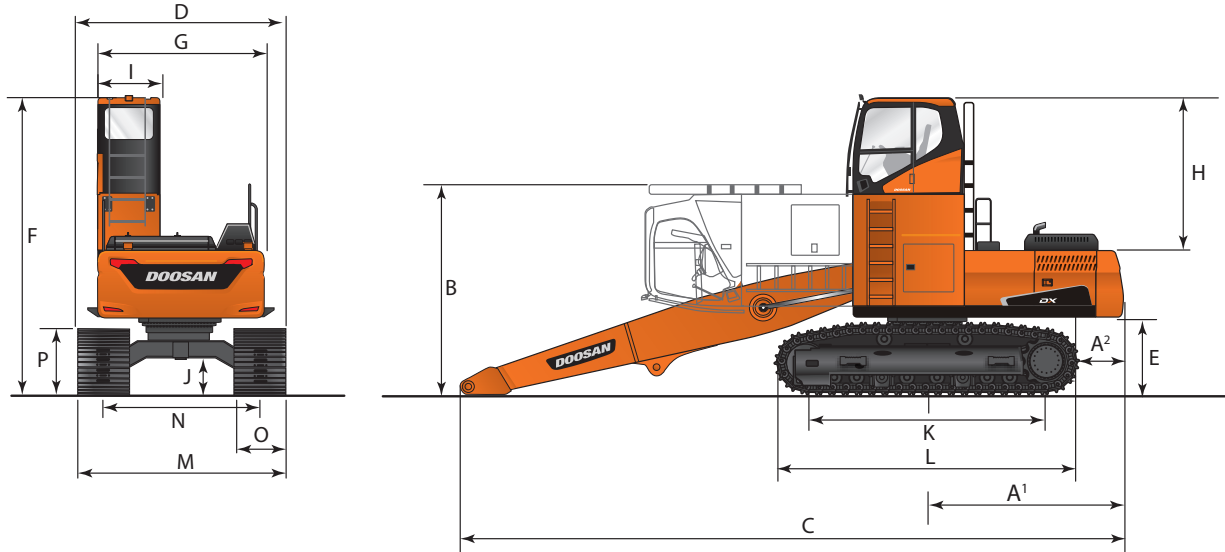

			DX225MH-5 Material Handler (US90)	DX300MH-5 Material Handler (US90)
BOOM		ft.-in. (mm)	21' 4" (6500)	25' 7" (7800)
ARM		ft.-in. (mm)	14' 9" (4500)	17' 9" (5400)
CAB TYPE			Fixed Cab Riser 3' 11" (1200)	Fixed Cab Riser 5' 11" (1800)
TAIL SWING RADIUS	A <sup>1</sup>	ft.-in. (mm)	9' 2" (2790)	10' 6" (3200)
TAIL SWING OVERHANG (REAR)	A <sup>2</sup>	ft.-in. (mm)	1' 10" (568)	2' 6" (760)
TAIL SWING OVERHANG (FRONT)	A <sup>3*</sup>	ft.-in. (mm)	1' 10" (568)	2' 6" (760)
TAIL SWING OVERHANG (SIDE)**	A <sup>4*</sup>	ft.-in. (mm)	3' 11" (1195)	4' 11" (1500)
SHIPPING HEIGHT	B	ft.-in. (mm)	11' 7" (3531)****	11' 5" (3480)****
SHIPPING LENGTH	C	ft.-in. (mm)	31' 1" (9480)	36' 1" (11,002)
SHIPPING WIDTH	D	ft.-in. (mm)	10' 6" (3190)	11' 2" (3400)
COUNTERWEIGHT CLEARANCE	E	ft.-in. (mm)	3' 4" (1010)	3' 4" (1020)
CABIN HEIGHT	F	ft.-in. (mm)	13' 9" (4200)	15' 11" (4860)
UPPER STRUCTURE WIDTH	G	ft.-in. (mm)	8' 11" (2710)	9' 9" (2960)
CABIN HEIGHT ABOVE HOUSE	H	ft.-in. (mm)	6' 8" (2040)	7' 8" (2345)
CABIN WIDTH	I	ft.-in. (mm)	3' 4" (1010)	3' 4" (1010)
CAR BODY CLEARANCE	J	ft.-in. (mm)	1' 7" (480)	1' 8" (505)
TUMBLER DISTANCE	K	ft.-in. (mm)	12' (3650)	13' 3" (4040)
OVERALL TRACK LENGTH	L	ft.-in. (mm)	14' 7" (4445)	16' 2" (4940)
UNDERCARRIAGE WIDTH	M	ft.-in. (mm)	10' 6" (3190)	11' 2" (3400)
TRACK GAUGE WIDTH	N	ft.-in. (mm)	6' 6" (1990)	8' 6" (2600)
TRACK SHOE WIDTH	O	ft.-in. (mm)	2' 8" (800)	2' 8" (800)
TRACK HEIGHT	P	ft.-in. (mm)	3' 1" (947)	3' 6" (1058)

\* Not Shown  
 \*\* Outrigger Width (Ground Level)  
 \*\*\* Dozer Lowered to Ground  
 \*\*\*\* With Fixed Cabin in Transport Position  
 or Elevating Cabin Lowered  
 \*\*\*\*\* Elevating Cabin Hose Guide

## Dimensions

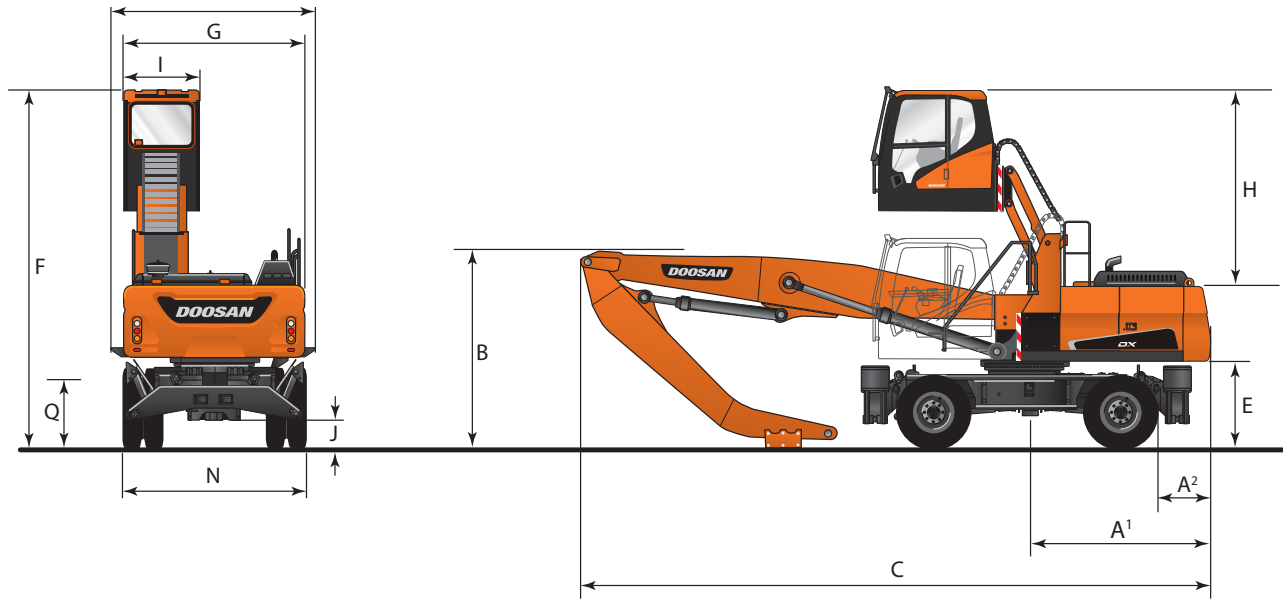

			DX210WMH-5 Material Handler (US90)
<b>BOOM</b>		ft.-in. (mm)	21' 4" (6500)
<b>ARM</b>		ft.-in. (mm)	14' 9" (4500)
<b>CAB TYPE</b>			Hydraulic Cab Riser 0.0" - 6' 5" (1950)
<b>TAIL SWING RADIUS</b>	A <sup>1</sup>	ft.-in. (mm)	8' 11" (2710)
<b>TAIL SWING OVERHANG (REAR)</b>	A <sup>2</sup>	ft.-in. (mm)	10.6" (268)
<b>TAIL SWING OVERHANG (FRONT)</b>	A <sup>3*</sup>	ft.-in. (mm)	6.7" (169)
<b>TAIL SWING OVERHANG (SIDE)**</b>	A <sup>4*</sup>	ft.-in. (mm)	3' 3" (978)
<b>SHIPPING HEIGHT</b>	B	ft.-in. (mm)	11' 9" (3580)*****
<b>SHIPPING LENGTH</b>	C	ft.-in. (mm)	31' 3" (9530)
<b>SHIPPING WIDTH</b>	D	ft.-in. (mm)	8' 2" (2500)
<b>COUNTERWEIGHT CLEARANCE</b>	E	ft.-in. (mm)	4' 2" (1260)
<b>CABIN HEIGHT</b>	F	ft.-in. (mm)	10' 7" (3225)**** 18' 1" (5520)
<b>UPPER STRUCTURE WIDTH</b>	G	ft.-in. (mm)	8' 4" (2530)
<b>CABIN HEIGHT ABOVE HOUSE</b>	H	ft.-in. (mm)	3' (923)**** 10' 6" (3218)
<b>CABIN WIDTH</b>	I	ft.-in. (mm)	3' 4" (1010)
<b>CAR BODY CLEARANCE</b>	J	ft.-in. (mm)	1' 2" (350)
<b>WHEEL BASE</b>	K <sup>1</sup>	ft.-in. (mm)	9' 4" (2850)
<b>TREAD WIDTH</b>	L <sup>1</sup>	ft.-in. (mm)	6' 3" (1914)
<b>BLADE WIDTH</b>	M <sup>1</sup>	ft.-in. (mm)	8' 4" (2530)
<b>OVERALL UNDERCARRIAGE LENGTH</b>	N <sup>1</sup>	ft.-in. (mm)	16' 8" (5080)
<b>OUTRIGGER LENGTH (REAR)</b>	O <sup>1</sup>	ft.-in. (mm)	3' 3" (999)
<b>OUTRIGGER LENGTH (FRONT)</b>	P <sup>1</sup>	ft.-in. (mm)	3' 8" (1116)
<b>BLADE LENGTH (FRONT)</b>	Q	ft.-in. (mm)	4' (1231)
<b>BLADE CLEARANCE (RAISED)</b>	R	ft.-in. (mm)	1' 6" (445)
<b>BLADE HEIGHT</b>	S	ft.-in. (mm)	2' 1" (630)
<b>MAX. BLADE DEPTH</b>	T	ft.-in. (mm)	4.9" (125)
<b>OUTRIGGER WIDTH (GROUND)</b>	U	ft.-in. (mm)	11' 4" (3465)
<b>OUTRIGGER WIDTH (MAX DEPTH)</b>	V	ft.-in. (mm)	11' 11" (3640)
<b>MAX. OUTRIGGER DEPTH</b>	W	ft.-in. (mm)	3.5" (90)
<b>TIRE SIZE</b>	-		8 x 10.00R20

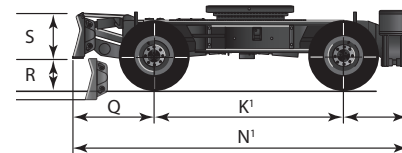
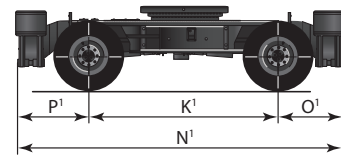
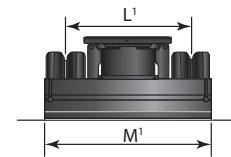
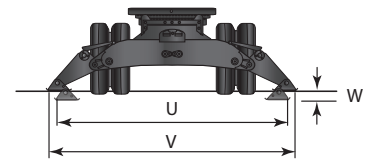

- \* Not Shown
- \*\* Outrigger Width (Ground Level)
- \*\*\* Dozer Lowered to Ground
- \*\*\*\* With Fixed Cabin in Transport Position  
or Elevating Cabin Lowered
- \*\*\*\*\* Elevating Cabin Hose Guide

# Working Range

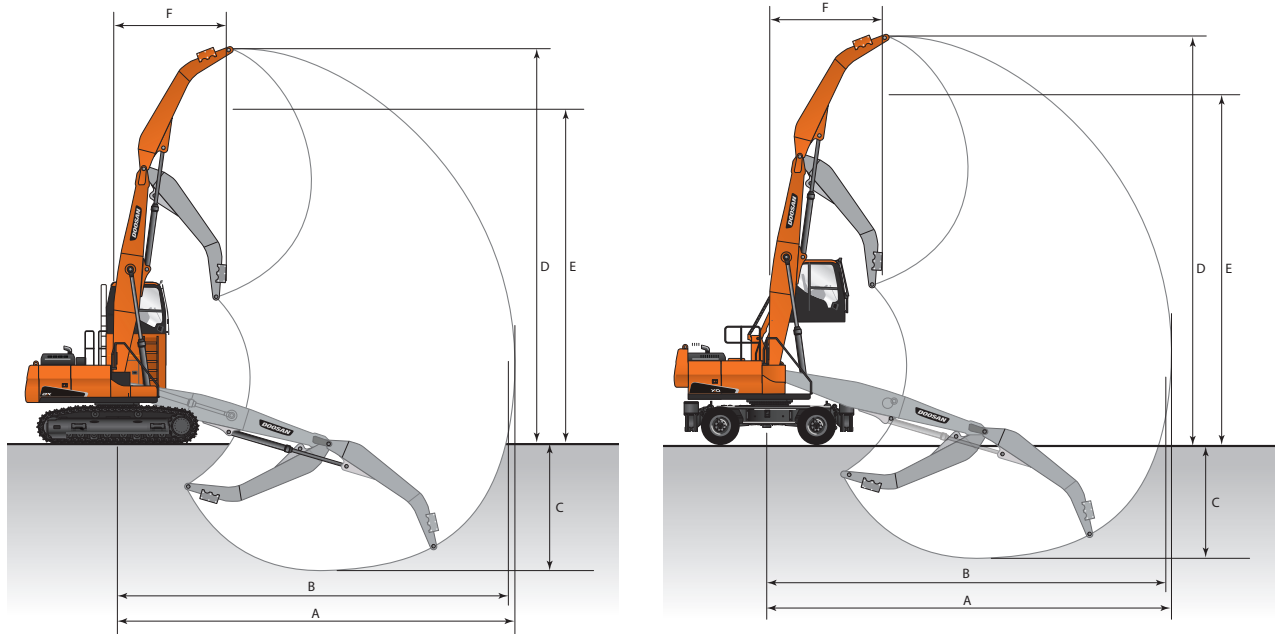

			DX225MH-5 Material Handler (US90)	DX300MH-5 Material Handler (US90)	DX210WMH-5 Material Handler (US90)
<b>BOOM</b>		ft.-in. (mm)	21' 4" (6500)	25' 7" (7800)	21' 4" (6500)
<b>ARM</b>		ft.-in. (mm)	14' 9" (4500)	17' 9" (5400)	14' 9" (4500)
<b>CAB TYPE</b>			Fixed Cab Riser 3' 11" (1200)	Fixed Cab Riser 5' 11" (1800)	Hydraulic Cab Riser 0.0" - 6' 5" (1950)
<b>MAX. REACH</b>	A	ft.-in. (mm)	35' 5" (10,800)	42' 8" (13,000)	35' 9" (10,900)
<b>MAX. REACH (GROUND)</b>	B	ft.-in. (mm)	35' (10,670)	42' (12,800)	35' 2" (10,720)
<b>MAX. DEPTH (PIN)</b>	C	ft.-in. (mm)	16' 9" (5100)	21' 8" (6600)	16' 5" (5000)
<b>MAX. HEIGHT (PIN)</b>	D	ft.-in. (mm)	40' (12,200)	46' 3" (14,100)	39' 8" (12,100)
<b>MAX. LOADING HEIGHT</b>	E	ft.-in. (mm)	31' 6" (9600)	37' 5" (11,400)	31' 2" (9500)
<b>MIN. SWING RADIUS</b>	F	ft.-in. (mm)	9' 11" (3020)	9' 7" (2915)	12' (3660)
<b>COUNTERWEIGHT</b>		lb. (kg)	12,787 (5800)	16,094 (7300)	11,244 (5100)
<b>OPERATING WEIGHT</b>		lb. (kg)	60,848 (27,600)	79,366 (36,000)	57,221 (25,955)

# Hydraulic Cylinders

	UNIT	DX225MH-5 Material Handler (US90)	DX300MH-5 Material Handler (US90)	DX210WMH-5 Material Handler (US90)
<b>BOOM (2)</b>				
BORE x ROD DIAMETER x STROKE	in. x in. x in. (mm x mm x mm)	4.9" x 3.3" x 49.6" (125 x 85 x 1260)	5.5" x 3.7" x 57.1" (140 x 95 x 1450)	4.7" x 3.3" x 48.2" (120 x 85 x 1225)
<b>ARM (1)</b>				
BORE x ROD DIAMETER x STROKE	in. x in. x in. (mm x mm x mm)	5.5" x 3.9" x 67.1" (140 x 100 x 1705)	5.9" x 4.1" x 69.1" (150 x 105 x 1755)	5.5" x 3.9" x 67.1" (140 x 100 x 1705)
<b>STEERING (1)</b>				
BORE x ROD DIAMETER x STROKE	in. x in. x in. (mm x mm x mm)	N/A	N/A	3.9" x 2" x 3.4" (100 x 50 x 86)
<b>LEVELING (1)</b>				
BORE x ROD DIAMETER x STROKE	in. x in. x in. (mm x mm x mm)	N/A	N/A	3.9" x 3.9" x 6" (100 x 100 x 153)
<b>DOZER (2)</b>				
BORE x ROD DIAMETER x STROKE	in. x in. x in. (mm x mm x mm)	N/A	N/A	5.1" x 3.1" x 6.3" (130 x 80 x 160)
<b>OUTRIGGER, REAR (2)</b>				
BORE x ROD DIAMETER x STROKE	in. x in. x in. (mm x mm x mm)	N/A	N/A	5.1" x 3.1" x 15.4" (130 x 80 x 391)
<b>CABIN TILTING (1)</b>				
BORE x ROD DIAMETER x STROKE	in. x in. x in. (mm x mm x mm)	4.5" x 2.0" x 33.7" (115 x 50 x 855)	4.5" x 2.0" x 33.7" (115 x 50 x 855)	N/A
<b>CABIN ELEVATING (2)</b>				
BORE x ROD DIAMETER x STROKE	in. x in. x in. (mm x mm x mm)	N/A	N/A	3.1" x 2.0" x 25.6" (80 x 50 x 650)

The piston rods and cylinder bodies are made of high-strength steel. A shock absorbing mechanism is fitted in all cylinders to ensure shock-free operation and extended piston life.

# Specifications

## Standard/Optional Equipment

- Standard Equipment
- Optional Equipment
- N/A

	DX225MH-5	DX300MH-5	DX210WMH-5
<b>ENGINE</b>			
Emissions (EPA)	T4	T4	T4
High Pressure Common Rail (HPCR)	•	•	•
Turbo, Waste Gate (WGT)	•	–	•
Turbo, Variable Geometry (VGT)	–	•	–
Cooled Exhaust Gas Recirculation (CEGR)	•	•	•
Exhaust Break	–	•	–
Diesel Oxidation Catalyst (DOC)	•	•	•
Selective Catalyst Reduction (SCR)	•	•	•
Diesel Exhaust Fluid (DEF)	•	•	•
Fuel Filter with Water Separator	•	•	•
Coolant Recovery Tank	•	•	•
Cooling Fan, Variable Speed - Radiator (Electric Clutch Direct Drive)	•	•	•
Dual Element Dry-Type Air Filter with Evacuator	•	•	•
Pre Cleaner	•	•	•
Electronic Engine Control	•	•	•
Auto-Idle	•	•	•
Auto Shutdown (Time-Adjustable)	•	•	•
Overheat & Low Oil Pressure Engine Protection	•	•	•
Block Heater (110V)	■	■	■
Diesel Powered Coolant Heater	■	■	■
Fuel Filler Pump	■	■	■
<b>HYDRAULIC</b>			
Electronic Power Optimizing System (EPOS)	•	•	•
Bent Axis Piston Main Pump (Tandem)	–	–	•
Variable Axial Piston Main Pump (Tandem)	•	•	–
Cross Sensing Pump Control	•	•	•
Pilot Operated Control Valves	•	•	•
Gear Pilot Pump	•	•	•
D-ECOPOWER	–	•	–
Smart Power Control (SPC)	•	•	•
Cooling Fan Variable Speed - Oil Cooler (Electric Clutch Direct Drive)	•	–	•
Cooling Fan Variable Speed - Oil Cooler (Hydraulic Motor)	–	•	–
Axial Piston Swing Motor	•	•	•
Spring Applied Hydraulic Release Brake, Travel	–	–	•
Spring Applied Hydraulic Release Brake, Swing	•	•	•
Axial Piston Travel Motor (High/Low, Auto)	•	•	–
Auxiliary Hydraulics, One-Way	•	•	•
Auxiliary Hydraulics, Two-Way	•	•	•
Auxiliary Hydraulics, Rotate	•	•	•
Adjustable Auxiliary Flow & Pressure, 10 Presets	•	•	•
Boom Lock Valves	•	•	•
Arm Lock Valve	•	•	•
<b>DRIVELINE</b>			
Transmission, 2-Speed Power-Shift with Creep	–	–	•
Planetary Drive (Front & Rear Axle)	–	–	•
Front Axle, Steerable & Oscillating (+-8°), Lockable	–	–	•
Rear Axle, Fixed	–	–	•
Dual Tires, 10.0-20-16PR	–	–	•
Solid Tires	–	–	■

	DX225MH-5	DX300MH-5	DX210WMH-5
<b>UNDERCARRIAGE</b>			
Track Guards and Chains with Adjusters	•	•	–
Track Rollers, Upper	2	2	–
Track Rollers, Lower	8	9	–
In-Shoe Motor Protection	•	•	–
Shoes, Triple Grouser - 800 mm	•	•	–
Shoes, Triple Grouser - 850 mm	–	■	–
Shoes, Triple Grouser - 900 mm	■	–	–
Shoes	49	48	–
Outrigger (2F / 2R)	–	–	•
<b>CABIN</b>			
Steel, All-Weather & Sound Suppressed	•	•	•
Cabin Riser - Fixed, 3' 11" (1200 mm)	•	–	–
Cabin Riser - Fixed, 5' 11" (1800 mm)	■	•	–
Cabin Riser - Hydraulic, 0.0" - 6' 5" (0 - 1950 mm)	■	■	•
Viscous Mount	•	•	•
Front Window with Wiper/Washer	•	•	•
Tinted Safety Glass	•	•	•
Skylight	•	•	•
Visor, Front Window and Skylight	•	•	•
Pull Up Type Top Front Window	•	•	•
Removable Lower Front Window with Storage Behind Seat	•	•	•
Adjustable Sliding Side Door Windows	•	•	•
Defrost, Front Window	•	•	•
Lockable Doors	•	•	•
Seat - Heated - Air Suspension - 2" (51 mm) Seat Belt - Adjustable Fore/Aft - Adjustable Height & Recline - Adjustable Arm Rests	•	•	•
3" (76 mm) Seat Belt	■	■	■
Control Stands - Height Adjustable - Mounted to Seat Base	•	•	•
Storage for Operator's Manuals	•	•	•
Mirrors	•	•	•
Fully Automatic HVAC w/ Ambient Temperature Sensor	•	•	•
7" Multi-Function LCD Monitor	•	•	•
Cigarette Lighter	•	•	•
AM/FM Stereo with CD Player & MP3 Port	•	•	•
Speakers (2)	•	•	•
Antenna, Roof Mounted	•	•	•
Emergency Breakout Tool	•	•	•
Hot/Cold Beverage Compartment	•	•	•
Power Socket, 12V	•	•	•
Beverage Holder	•	•	•
Interior Light	•	•	•
Coat Hanger	•	•	•
Rain Shield	■	■	■
Guard, FOGS	■	■	■
Guard, Front Window	■	■	■
Vandalism Covers (Windows)	■	■	■

	DX225MH-5	DX300MH-5	DX210WMH-5
<b>ELECTRICAL</b>			
System Voltage - 24V	•	•	•
Alternator - 12V, 80 Amp	•	–	•
Alternator - 12V, 100 Amp	–	•	–
2 x 12V Batteries, 150 AH Reserve Capacity	•	–	•
2 x 12V Batteries, 200 AH Reserve Capacity	–	•	–
Blade Type Fuse Panel	•	•	•
Main Circuit Breaker	•	•	•
Light, Work (Halogen): Machine (2), Boom (2)	•	•	•
Light, Work (Halogen): Cabin (2 Front)	■	■	■
Light, Work (Halogen): Cabin (4 Front, 2 Rear)	■	■	■
Lights, Street with Brake Lights	–	–	•
Rotating Beacon	■	■	■
Hour Meter	•	•	•
Engine Restart Prevention System	•	•	•
Rear View Camera	•	•	•
Side View Camera (Right Side)	■	■	■
Laptop Service Port	•	•	•
Self-Diagnostics System	•	•	•
Doosan Connect Telematics	•	•	•
<b>CONTROLS</b>			
Joystick Controls	•	•	•
Pattern Control Change Valve (SAE, ISO)	•	•	•
Joystick Attachment Control Switches/Buttons - One-way - Two-way - Power Boost	•	•	•
Foot Pedal Attachment Control	•	•	–
Control Stands - Height Adjustable - Sliding - Fore/Aft	•	•	•
Engine Speed Control Dial	•	•	•
Travel Pedals with Hand Levers	•	•	–
Straight Travel Pedal	■	■	–
Switches, Console Mounted - Starter (Key) - Travel Speed Selector - Work Light - Auxiliary Mode Switch - Oscillation Lock (DX210WMH-5 only) - Parking Brake (DX210WMH-5 only) - Outrigger Selection (DX210WMH-5 only) - Cruise Control (DX210WMH-5 only) - Road Lights (DX210WMH-5 only)	•	•	•
Switches & Indicators, Steering Column - Steering Column Positional Lever - Work/Travel Selector Switch - Turn Signal Control Lever - Hazard Warning Switch - Turn Signal/Hazard Light Indicator - Wiper & Washer Control - Horn Button - High/Low Beam Control	–	–	•
Emergency Stop Switch	•	•	•
Power Mode (P+, P, S, E)	•	•	•
Work Mode (Digging, Lifting, Breaker, Shear)	•	•	•
Smart Power Control (SPC)	•	•	•
Jog Dial Display Control	•	•	•
Wiper Control Panel	•	•	•
Audio Control Panel	•	•	•
Steering Console	–	–	•
Adjustable Steering Column - Tilting - Telescoping	–	–	•
Throttle Pedal (Accelerator)	–	–	•

	DX225MH-5	DX300MH-5	DX210WMH-5
<b>CONTROLS CONT.</b>			
Break Pedal	–	–	•
Joystick Machine Control Switches/Buttons - FNR - Horn - Deceleration	–	–	•
Emergency Steering	–	–	•
<b>DISPLAY MONITOR &amp; WARNINGS</b>			
Buzzer - Engine Oil Pressure - Coolant Temperature	•	•	•
Gauges - Fuel Level - DEF Level - Engine Coolant Temperature - Hydraulic Oil Temperature - Engine RPM - Battery Voltage - Hydraulic Pump Pressure - ECO - Digital Clock - Trip Meter - Hour Meter	•	•	•
Warning & Indicator Lights - Seat Belt - Engine Pre-Heat Engaged - Check Engine - Fuel Level - DEF Level - Engine Oil Pressure - Hydraulic Oil Temperature - Hydraulic Charge Pressure - Radiator Coolant Level & Temp - Hydraulic Pilot Filter - Hydraulic Return Filter - SCR Warning - Battery Charge - Water in Fuel - Air Filter - Work Lights On - Error Code	•	•	•
Swing Alarm	•	•	■
Travel Alarm	•	•	•
<b>OTHER</b>			
Centralized Lubrication - Boom - Arm - Swing Bearing	•	•	•
Handrails & Service Platforms	•	•	•
Skid-Resistant Steps & Service Platforms	•	•	•
Wheel Chocks	–	–	•
V-shape Upper Side Guards	■	■	■
Cat-Walk	■	■	■
Manuals - Operations & Maintenance - Parts - AEM Safety Manual	•	•	•
Doosan Connect Three-Year Subscription	•	•	•
Vandalism Protection - Lockable Panels - Lockable Fluid Fill Points - Anti-Theft Protection (Password)	•	•	•
Toolbox	–	–	•
Air Compressor	■	■	■

# Specifications

## Lifting Capacity

**DX225MH** (US90)

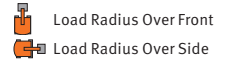

Boom, Std: 21' 4" (6500 mm) Arm: 14' 9" (4500 mm) Counter Weight: 12,787 lb. (5800 kg) Track Shoe: 2' 8" (800) Bucket: None Unit: lb. (kg)

A (ft.) B (ft.)	10' (3.0 m)		15' (4.5 m)		20' (6.0 m)		25' (7.5 m)		30' (9 m)		35' (10.5 m)		MAX. REACH			
															A	
40' (12 m)														* 18,730 (* 8670)	* 18,730 (* 8670)	11' 9" 3.58
35' (10.5 m)					* 12,740 (* 5710)	* 12,740 (* 5710)								* 12,680 (* 5600)	* 12,680 (* 5600)	20' 5" 6.46
30' (9 m)					* 11,650 (* 5290)	* 11,650 (* 5290)	* 10,820 (* 4900)	10,330 (4820)						* 10,710 (* 4800)	9540 (4220)	26' 2" 8.11
25' (7.5 m)					* 11,520 (* 5270)	* 11,520 (* 5270)	* 10,510 (* 4800)	10,430 (4800)	* 9760 (* 4440)	7690 (3590)				* 9750 (* 4400)	7670 (3430)	30' 9.23
20' (6 m)			* 13,900 (* 6400)	* 13,900 (* 6400)	* 12,040 (* 5530)	* 12,040 (* 5530)	* 10,690 (* 4900)	10,310 (4790)	* 9660 (* 4420)	7710 (3590)				* 9160 (* 4140)	6660 (3000)	32' 8" 10
15' (4.5 m)			* 15,980 (* 7380)	* 15,980 (* 7380)	* 13,070 (* 6020)	* 13,070 (* 6020)	* 11,180 (* 5140)	10,030 (4650)	* 9810 (* 4510)	7590 (3520)	(* 3950)	(2750)		* 8720 (* 3950)	6080 (2750)	34' 5" 10.51
10' (3 m)			* 18,720 (* 8660)	* 18,720 (* 8660)	* 14,340 (* 6620)	13,350 (6190)	* 11,780 (* 5430)	9670 (4480)	* 10,020 (* 4610)	7400 (3430)	* 8480 (* 3930)	5850 (2720)		* 8350 (* 3780)	5760 (2610)	35' 4" 10.78
5' (1.5 m)			* 20,870 (* 9650)	18,930 (8780)	* 15,380 (* 7090)	12,670 (5870)	* 12,230 (* 5640)	9300 (4310)	* 10,110 (* 4670)	7200 (3340)	* 8240 (* 3840)	5770 (2680)		* 7980 (* 3620)	5650 (2560)	35' 6" 10.83
0 Ground Line	* 6770 (* 2940)	* 6770 (* 2940)	* 21,290 (* 9810)	18,050 (8370)	* 15,680 (* 7240)	12,160 (5640)	* 12,280 (* 5670)	9010 (4170)	* 9890 (* 4580)	7040 (3260)	* 7560 (* 3580)	5720 (2650)		* 7550 (* 3420)	5720 (2590)	35' 10.67
-5' (-1.5 m)	* 10,130 (* 4480)	* 10,130 (* 4480)	* 19,840 (* 9150)	17,700 (8210)	* 14,960 (* 6910)	11,880 (5510)	* 11,670 (* 5400)	8840 (4090)	* 9110 (* 4250)	6960 (3220)				* 6970 (* 3170)	6000 (2720)	33' 9" 10.3
-10' (-3 m)	* 13,840 (* 6140)	* 13,840 (* 6140)	* 16,820 (* 7770)	* 16,820 (* 7770)	* 13,070 (* 6060)	11,830 (5480)	* 10,120 (* 4720)	8810 (4080)	* 7330 (* 3490)	6990 (3230)				* 6090 (* 2780)	6090 (2780)	31' 8" 9.67
-15' (-4.5 m)			* 12,230 (* 5710)	* 12,230 (* 5710)	* 9770 (* 4590)	* 9770 (* 4590)	* 7170 (* 3440)	* 7170 (* 3440)								

**DX300MH-5** (US90)















Boom, Std: 18' 4" (5600 mm) Arm: 9' (2750 mm) Counter Weight: 8818 lb. (4000 kg) Track Shoe: 2' 8" (800) Bucket: None Unit: lb. (kg)

A (ft.) B (ft.)	10' (3.0 m)		15' (4.5 m)		20' (6.0 m)		25' (7.5 m)		30' (9 m)	
45' (13.5 m)										
40' (12 m)								* 15,980 (* 7180)	15,910 (7180)	
35' (10.5 m)								* 14,910 (* 6770)	* 14,910 (* 6770)	* 14,180 (* 6420)
30' (9 m)								* 14,710 (* 6720)	* 14,710 (* 6720)	* 13,780 (* 6290)
25' (7.5 m)								* 16,650 (* 7650)	* 16,650 (* 7650)	* 15,120 (* 6930)
20' (6 m)								* 18,210 (* 8390)	* 18,210 (* 8390)	* 16,000 (* 7360)
15' (4.5 m)								* 20,440 (* 9440)	* 20,440 (* 9440)	* 17,240 (* 7,940)
10' (3 m)								* 30,620 (* 14,190)	29,880 (13,830)	* 22,900 (* 10,580)
5' (1.5 m)								* 15,590 (* 6410)	* 15,590 (* 6410)	* 14,960 (* 6910)
0 Ground Line								* 12,190 (* 5240)	* 12,190 (* 5240)	* 25,610 (* 11,820)
-5' (-1.5 m)	* 7040 (* 3110)	* 7040 (* 3110)	* 13,870 (* 6060)	* 13,870 (* 6060)	* 25,050 (* 11,560)	17,050 (7910)	* 19,840 (* 9160)	12,640 (5860)	15,730 (7290)	9940 (4600)
-10' (-3 m)	* 10,780 (* 4780)	* 10,780 (* 4780)	* 16,890 (* 7420)	* 16,890 (* 7420)	* 23,150 (* 10,700)	16,900 (7840)	* 18,570 (* 8590)	12,500 (5790)	* 15,100 (* 7010)	9840 (4560)
-15' (-4.5 m)	* 14,350 (* 6380)	* 14,350 (* 6380)	* 20,550 (* 9050)	* 20,550 (* 9050)	* 19,940 (* 9250)	17,020 (7890)	* 16,180 (* 7530)	12,560 (5810)	* 12,980 (* 6070)	9900 (4580)
-20' (-6 m)							* 15,200 (* 7130)	* 15,200 (* 7130)	* 12,340 (* 5840)	* 9230 (* 4470)

A (ft.) B (ft.)	35' (10.5 m)		40' (12 m)		MAX. REACH	
45' (13.5 m)					* 19,010 (* 8240)	* 19,010 (* 8240)
40' (12 m)					* 15,210 (* 6780)	14,740 (6380)
35' (10.5 m)					* 13,600 (* 6110)	10,970 (* 4850)
30' (9 m)	* 13,110 (* 5960)	9270 (4340)			* 12,750 (* 5760)	9040 (4040)
25' (7.5 m)	* 12,950 (* 5920)	9310 (4340)			12,040 (5420)	7900 (3550)
20' (6 m)	* 13,120 (* 6020)	9180 (4270)	11,180 (5210)	7290 (3400)	11,020 (4970)	7170 (3240)
15' (4.5 m)	* 13,430 (* 6170)	8960 (4160)	11,090 (5160)	7200 (3350)	10,380 (4700)	6710 (3040)
10' (3 m)	13,380 (6210)	8700 (4040)	10,950 (5090)	7070 (3290)	10,030 (4550)	6440 (2920)
5' (1.5 m)	13,110 (6080)	8440 (3920)	10,810 (5020)	6940 (3220)	9910 (4500)	6340 (2880)
0 Ground Line	12,880 (5970)	8230 (3820)	10,700 (4960)	6830 (3170)	10,020 (4540)	6390 (2900)
-5' (-1.5 m)	12,730 (5900)	8090 (3750)	10,660 (4930)	6790 (3140)	* 10,060 (* 4570)	6620 (3000)
-10' (-3 m)	* 12,150 (* 5680)	8060 (3730)			* 9370 (* 4260)	7060 (3190)
-15' (-4.5 m)	* 9680 (* 4650)	8180 (3780)			* 8330 (* 3810)	7810 (3520)
-20' (-6 m)						11.18

## DX210WMH-5 (US90)

Boom, Std: 21' 4" (6500 mm) Arm: 14' 9" (4500 mm) Counter Weight: 11,244 lbs. (5100 kg) Tire Size: 10.00R20 Bucket: None Unit: lb. (kg)

A (ft.) B (ft.)	10' (3.0 m)		15' (4.5 m)		20' (6.0 m)		25' (7.5 m)		30' (9 m)		35' (10.5 m)		MAX. REACH		A		
																	
40' (12 m)															(* 9080)	(* 9080)	3.9
35' (10.5 m)					* 13,920 (* 6270)	* 13,920 (* 6270)									* 13,710 (* 6060)	* 13,710 (* 6060)	21' 6.64
30' (9 m)					* 12,910 (* 5880)	* 12,910 (* 5880)	* 11,820 (* 5370)	* 11,820 (* 5370)							* 11,570 (* 5190)	* 11,570 (* 5190)	26' 8" 8.25
25' (7.5 m)					* 12,840 (* 5880)	* 12,840 (* 5880)	* 11,560 (* 5290)	* 11,560 (* 5290)	* 10,560 (* 4820)	9770 (4560)					* 10,490 (* 4730)	9530 (4270)	30' 5" 9.35
20' (6 m)					* 13,420 (* 6170)	* 13,420 (* 6170)	* 11,780 (* 5410)	* 11,780 (* 5410)	* 10,500 (* 4820)	9770 (4540)					* 9770 (* 4420)	8320 (3750)	33' 10.1
15' (4.5 m)			* 17,980 (* 8320)	* 17,980 (* 8320)	* 14,520 (* 6690)	* 14,520 (* 6690)	* 12,290 (* 5650)	* 12,290 (* 5650)	* 10,650 (* 4900)	9630 (4470)		(* 4230)	(3500)	* 9250 (* 4180)	7640 (3450)	34' 8" 10.59	
10' (3 m)			* 20,830 (* 9,640)	* 20,830 (* 9,640)	* 15,800 (* 7290)	* 15,800 (* 7290)	* 12,850 (* 5920)	12,380 (5740)	* 10,820 (* 4990)	9420 (4370)		* 9020 (* 4190)	7450 (3460)	* 8770 (* 3970)	7270 (3300)	35' 7" 10.84	
5' (1.5 m)			* 22,790 (* 10,520)	* 22,790 (* 10,520)	* 16,720 (* 7720)	16,620 (7710)	* 13,210 (* 6100)	11,980 (5560)	* 10,810 (* 5000)	9210 (4270)		* 8670 (* 4050)	7320 (3420)	* 8280 (* 3750)	7160 (3250)	35' 9" 10.89	
0 Ground Line	* 6940 (* 3030)	* 6940 (* 3030)	* 22,650 (* 10,010)	* 22,650 (* 10,010)	* 16,740 (* 7720)	16,060 (7460)	* 13,060 (* 6030)	11,670 (5410)	* 10,420 (* 4830)	9040 (4190)		* 7810 (* 3710)	7310 (3390)	* 7690 (* 3490)	7270 (3300)	35' 2" 10.72	
-5' (-1.5 m)	* 10,620 (* 4700)	* 10,620 (* 4700)	* 20,490 (* 9440)	* 20,490 (* 9440)	* 15,580 (* 7200)	* 15,580 (* 7200)	* 12,120 (* 5620)	11,480 (5320)	* 9,370 (* 4380)	8950 (4150)				* 6930 (* 3150)	* 6930 (* 3150)	33' 10" 10.32	
-10' (-3 m)	* 14,580 (* 6470)	* 14,580 (* 6470)	* 16,670 (* 7710)	* 16,670 (* 7710)	* 13,140 (* 6100)	* 13,140 (* 6100)	* 10,150 (* 4740)	* 10,150 (* 4740)	* 7190 (* 3450)	* 7190 (* 3450)				* 5810 (* 2660)	* 5810 (* 2660)	31' 8" 9.68	
-15' (-4.5 m)			* 11,240 (* 5270)	* 11,240 (* 5270)	* 9180 (* 4340)	* 9180 (* 4340)	* 6640 (* 3210)	* 6640 (* 3210)									

## Grapple

		DXG4063	DXG4100
APPROVED MACHINE(S)		DX225MH-5 DX210WMH-5	DX300MH-5
CAPACITY	yd <sup>3</sup> (m <sup>3</sup> )	0.63 (0.50)	1.04 (0.80)
WEIGHT	lb. (kg)	3064 (1390)	3638 (1650)
HEIGHT (OPEN)	A ft.-in. (mm)	7' 8" (2326)	8' 3" (2517)
WIDTH (OPEN)	B ft.-in. (mm)	7' 2" (2183)	8' 3" (2519)
CLEARANCE (OPEN)	C ft.-in. (mm)	6' (1838)	6' 11" (2112)
HEIGHT (CLOSED)	D ft.-in. (mm)	8' 6" (2600)	9' 2" (2800)
WIDTH (CLOSED)	E ft.-in. (mm)	4' 8" (1420)	5' 5" (1661)
CLEARANCE (CLOSED)	F ft.-in. (mm)	3' 6" (1079)	4' 2" (1269)
WIDTH (SQUARE)	G ft.-in. (mm)	5' 5" (1643)	6' 2" (1882)
UNDERSLUNG MOUNT*	ft.-in. (mm)	2.6" (65)	2.6" (65)
ROTATION	rpm @ gpm (L/m)	12 @ 4.3 (16)	12 @ 7.1 (27)

\* = not shown

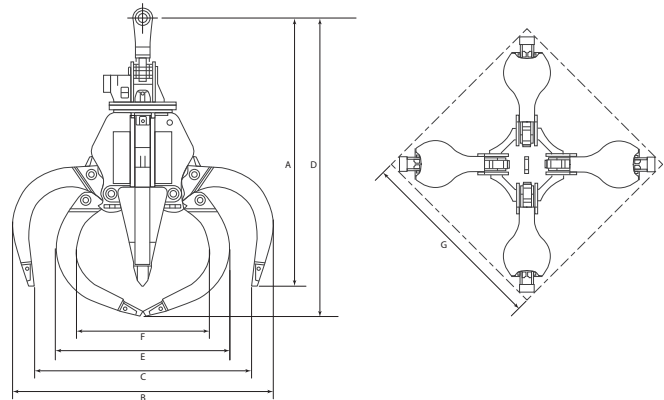

## Magnet

		40" MAGNET	48" MAGNET	58" MAGNET
APPROVED MACHINE(S)		DX225MH-5* DX300MH-5*	DX225MH-5 DX210WMH-5	DX300MH-5
DIAMETER	ft.-in. (mm)	40" (1016)	48" (1219)	58" (1473)
LIFT CAPACITY (HM#1)	lb. (kg)	1250 (567)	1925 (866)	3025 (1361)
LIFT CAPACITY (HM#2)	lb. (kg)	775 (352)	1275 (574)	1975 (889)
LIFT CAPACITY (TURNINGS)	lb. (kg)	400 (181)	525 (236)	800 (360)
DUTY CYCLE	%	75%	75%	75%
AMPS (COLD)	A	32	44	65
VOLTAGE, DC	V	230	230	230
SLING TYPE	ft.-in. (mm)	Chain	Chain	Chain

\* For underslinging

# DOOSAN STRONG



Printed on 10% recycled paper

1.877.745.7814

[DoosanEquipment.com/MH](http://DoosanEquipment.com/MH)

Doosan® and the Doosan logo are registered trademarks of Doosan Corp. in the United States and various other countries around the world. ©2018 Doosan Infracore North America, LLC. All rights reserved.

**DOOSAN**